

SENSYLINK Microelectronics

(CHT8310)

Low Voltage Digital Humidity & Temperature Sensor

CHT8310 is a Low Voltage Digital Humidity and Temperature Sensor with typical accuracy of $\pm 2\%RH$ and $\pm 0.2^{\circ}C$. It is compatible with SMBus, I²C Interface. It is ideally used in HVAC, environment monitor etc.

Low Voltage Digital Humidity and Temperature Sensor

Description

CHT8310 is a low voltage digital humidity and temperature sensor with $\pm 2\%RH$ (Typ.) accuracy for humidity and $\pm 0.2^{\circ}C$ (Typ.) accuracy for temperature. Humidity and Temperature data can be read out directly via digital interface by MCU, Bluetooth Chip or SoC chip.

The digital interface is compatible with SMBus and I²C protocol. Also it supports communication with fast speed (up to 400kHz) and high speed (up to 1.0MHz) for I²C protocol.

Each chip is specially calibrated for temperature and humidity accuracy in factory before shipment to customers. There is no need for re-calibration anymore.

It includes a high precision band-gap circuit, an analog to digital converter, a calibration unit with non-volatile memory, and a digital interface block.

It has ALERT logic output pin with open drain structure, which is active low or high.

The chip supports up to 4 devices in one I²C bus by setting different slave address via AD0 pin.

Available Package: DFN3x3-6 package

Features

- Operation Voltage: 1.65V to 5.5V
- Average Operating Current: 2.0uA (Typ.)@ 3.3V, 1Con/s for Both temperature and humidity Conversion
- Standby Current: 55nA(Typ.)
- Temperature Accuracy with calibration:
 - ±0.2°C(Typ.) from 0°C to 80°C
 - ±0.4°C(Typ.) from -20°C to 100°C
 - ±0.5°C(Typ.) from -40°C to 125°C
- Humidity Accuracy with calibration:
 - ±2%RH(Typ.) from 20%RH to 80%RH
- Digital Interface compatible with SMBus and I²C, support:
 - Up to 4 different slave addresses by setting AD0 pin
 - Packet Error Checking feature to improve communication reliability and robustness
 - Speed up to 1.0MHz
 - SMBus timeout feature
 - SMBus Alert Response Alert (ARA)
 - SMBus General Call
- Programmable High/Low Limit Alert for Temperature and/or Humidity
- Supports One shot or continuous measurement
- Temperature Range: -40°C to 125 °C
- Humidity Range: 0%RH to 100%RH

Applications

- Smart HVAC System
- Environment Monitor
- Portable/Wearable Weather Monitor

PIN Configurations (Top View)

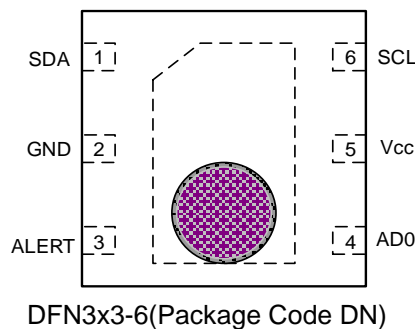

Typical Application

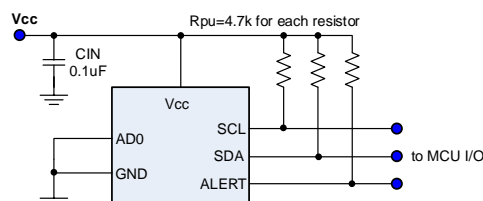

Figure 1. Typical Application of CHT8310

Low Voltage Digital Humidity and Temperature Sensor

Pin Description

PIN No.	PIN Name	Description
1	SDA	Digital interface data input or output pin, need a pull-up resistor to Vcc.
2	GND	Ground pin.
3	ALERT	To Indicate alert status of over Humidity and/or Temperature limitation programmed by setting temperature and/or high/low-limit registers. Need a pull-up resistor to Vcc in application. It is open drain output with active low or high by setting POL bit.
4	AD0	Slave Address selection pin, the chip can be defined total 4 different slave addresses by connecting this pin to GND, Vcc, SCL or SDA pin respectively. If leave this pin open, address is 0x80. See Slave Address for detail.
5	Vcc	Power supply input pin, using 0.1uF low ESR ceramic capacitor to ground
6	SCL	Digital interface clock input pin, need a pull-up resistor to Vcc.
	Thermal Pad	Not connected with any internal pin

Function Block

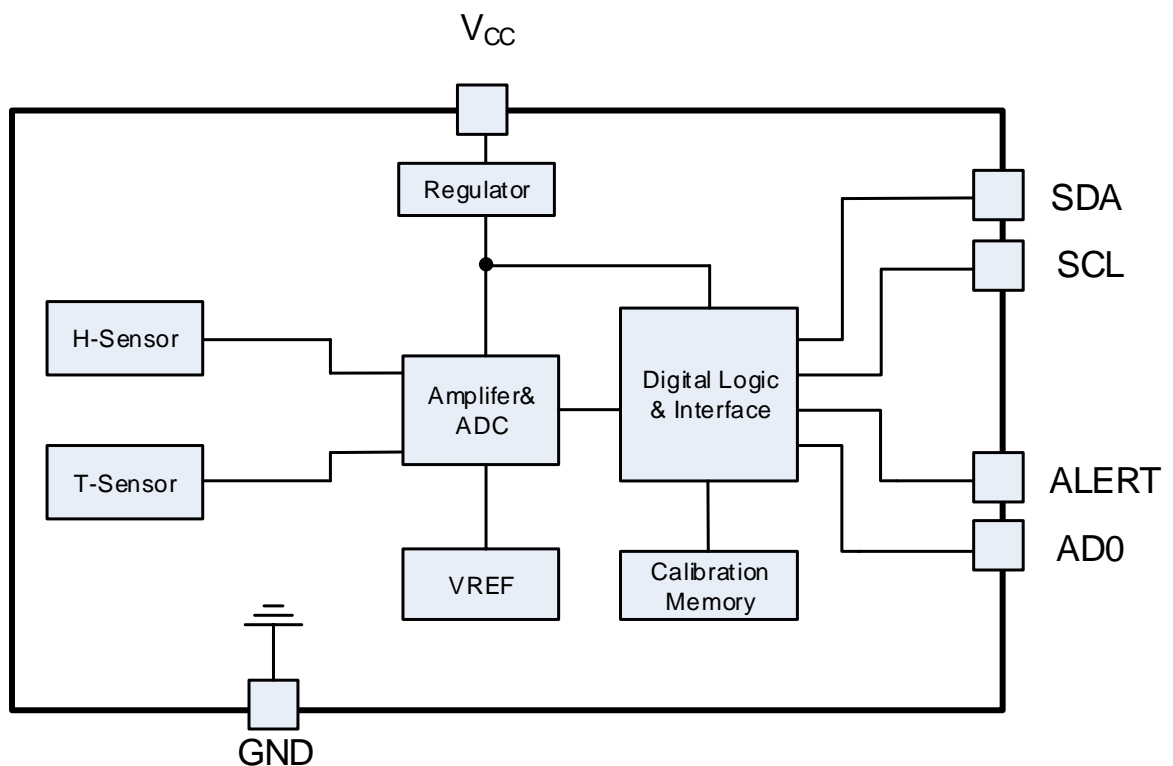
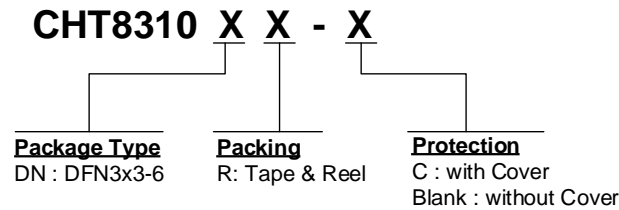

Figure 2. CHT8310 function block

Low Voltage Digital Humidity and Temperature Sensor

Ordering Information



Order PN	Accuracy	Green ¹	Package	Marking ID ²	Packing	MPQ	Operation Temperature	Protection Cover
CHT8310DNR	±0.2°C ±2.0%RH	Halogen free	DFN3x3-6	8310 YWWAXX	Tape & Reel	3,000	-40°C~+125°C	No
CHT8310DNR-C	±0.2°C ±2.0%RH	Halogen free	DFN3x3-6	8310 YWWAXX	Tape & Reel	3,000	-40°C~+125°C	Yes

Notes

1. Sensylink can meet RoHS 2.0/REACH requirement. So most package types Sensylink offers only states halogen free, instead of lead free.
2. Marking ID includes 2 rows of characters. In general, the 1st row of characters are part number, and the 2nd row of characters are date code plus production information.



SENSYLINK Microelectronics Inc.

www.sensylink.com

IMPORTANT NOTICE

SENSYLINK Microelectronics Inc. reserves the right to make modifications, enhancements, improvements, corrections or other changes without further notice to this document and any product described herein or to discontinue any product or service. Customers should obtain the latest relevant information before placing orders and should verify the latest and complete information. SENSYLINK Microelectronics does not assume any responsibility for use of any product, nor does SENSYLINK Microelectronics any liability arising out of the application or use of this document or any product or circuit described herein. SENSYLINK Microelectronics assumes no liability for applications assistance or the design of Customers' products. Customers are responsible for their products and applications using SENSYLINK Microelectronics components. SENSYLINK Microelectronics does not convey any license under its patent or trademark rights nor the other rights.

SENSYLINK Microelectronics Inc. © 2015 - 2023.